

Please check the examination details below before entering your candidate information

Candidate surname

Other names

Centre Number

Candidate Number

--	--	--	--	--

--	--	--	--	--

Pearson Edexcel International GCSE (9-1)

Thursday 15 May 2025

Morning (Time: 2 hours)

Paper
reference

4WM1H/01R

Mathematics A (Modular)

UNIT 1H

Higher Tier



You must have: Ruler graduated in centimetres and millimetres, protractor, pair of compasses, pen, HB pencil, eraser, calculator. Tracing paper may be used.

Total Marks

Instructions

- Use **black** ink or ball-point pen.
- **Fill in the boxes** at the top of this page with your name, centre number and candidate number.
- Answer **all** questions.
- Without sufficient working, correct answers may be awarded no marks.
- Answer the questions in the spaces provided
– *there may be more space than you need.*
- **Calculators may be used.**
- You must **NOT** write anything on the formulae page.
- Anything you write on the formulae page will gain **NO** credit.

Information

- The total mark for this unit is 100.
- The marks for **each** question are shown in brackets
– *use this as a guide as to how much time to spend on each question.*

Advice

- Read each question carefully before you start to answer it.
- Check your answers if you have time at the end.

Turn over ►

P81635A

©2025 Pearson Education Ltd.
Y:1/1/1/1/



Pearson

International GCSE Mathematics

Formulae sheet – Higher Tier

Arithmetic series

Sum to n terms, $S_n = \frac{n}{2} [2a + (n - 1)d]$

The quadratic equation

The solutions of $ax^2 + bx + c = 0$ where $a \neq 0$ are given by:

$$x = \frac{-b \pm \sqrt{b^2 - 4ac}}{2a}$$

Area of trapezium = $\frac{1}{2}(a + b)h$

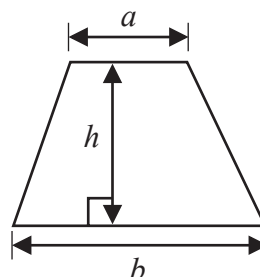

Trigonometry

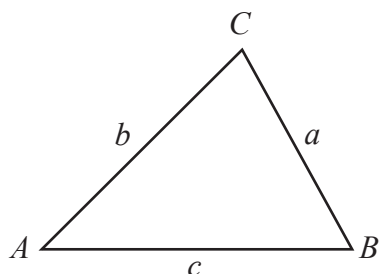

In any triangle ABC

Sine Rule $\frac{a}{\sin A} = \frac{b}{\sin B} = \frac{c}{\sin C}$

Cosine Rule $a^2 = b^2 + c^2 - 2bc \cos A$

Area of triangle = $\frac{1}{2}ab \sin C$

Volume of cone = $\frac{1}{3}\pi r^2 h$

Curved surface area of cone = $\pi r l$

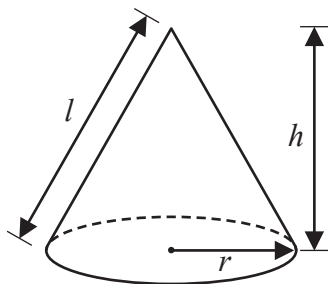

Volume of prism

= area of cross section \times length

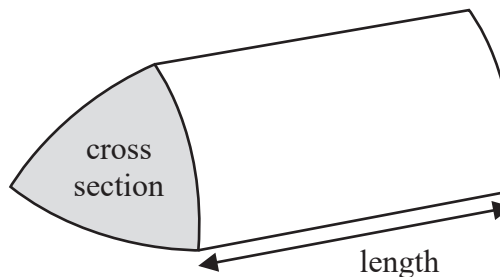

Volume of cylinder = $\pi r^2 h$

Curved surface area of cylinder = $2\pi r h$

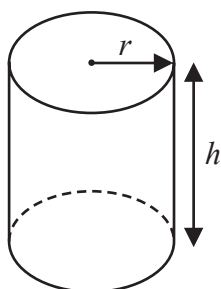

Volume of sphere = $\frac{4}{3}\pi r^3$

Surface area of sphere = $4\pi r^2$

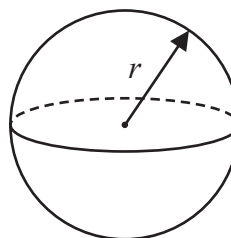

DO NOT WRITE IN THIS AREA

DO NOT WRITE IN THIS AREA

DO NOT WRITE IN THIS AREA



DO NOT WRITE IN THIS AREA

DO NOT WRITE IN THIS AREA

DO NOT WRITE IN THIS AREA

Answer ALL TWENTY FOUR questions.

Write your answers in the spaces provided.

You must write down all the stages in your working.

1 The length of a ship is 142.8 m, correct to 1 decimal place.

(i) Write down the lower bound of the length of the ship.

..... m
(1)

(ii) Write down the upper bound of the length of the ship.

..... m
(1)

(Total for Question 1 is 2 marks)

2 Show that $2\frac{1}{4} \times 1\frac{5}{7} = 3\frac{6}{7}$

(Total for Question 2 is 3 marks)



- 3 Here is a biased 5-sided spinner.
When the spinner is spun, it can land on blue or on green or on purple or on red or on yellow.

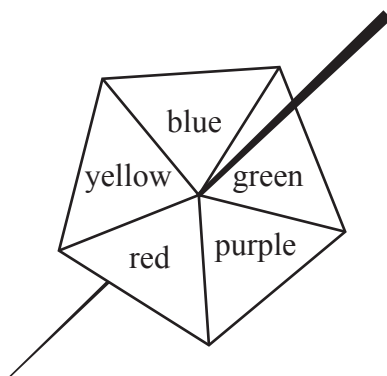

The table gives information about the probability of the spinner landing on each colour.

Colour	blue	green	purple	red	yellow
Probability	0.12	0.20	0.38	$4x$	x

Sophie spins the spinner once.

- (a) Work out the probability that the spinner lands on blue or on green or on purple.

.....
(1)

Max spins the spinner 350 times.

- (b) Work out an estimate for the number of times the spinner lands on red.

.....
(4)

(Total for Question 3 is 5 marks)



4 $\mathcal{E} = \{1, 2, 3, 4, 5, 6, 7, 8, 9, 10, 11, 12\}$

$A = \{2, 4, 6, 8, 10, 12\}$

$B = \{3, 6, 9, 12\}$

$C = \{1, 3, 5, 7, 9, 11\}$

(a) List the members of the set

(i) $A \cup B$

.....

(ii) B'

.....

(2)

$\mathcal{E} = \{1, 2, 3, 4, 5, 6, 7, 8, 9, 10, 11, 12\}$

$A = \{2, 4, 6, 8, 10, 12\}$

$B = \{3, 6, 9, 12\}$

$C = \{1, 3, 5, 7, 9, 11\}$

\mathcal{E}	\cap	\cup	\emptyset	\in	\notin
---------------	--------	--------	-------------	-------	----------

(b) Write a symbol from the box on each dotted line to make each of the following a true statement.

(i) $A \cap C = \dots\dots\dots$

(ii) $13 \dots\dots\dots \mathcal{E}$

(2)

(Total for Question 4 is 4 marks)



5 $3^8 \times 3^4 = 3^m$

(a) Find the value of m

$$m = \dots\dots\dots (1)$$

$$4^{12} \div 4^7 = 4^n$$

(b) Find the value of n

$$n = \dots\dots\dots (1)$$

$$(6^2)^{10} = 6^p$$

(c) Find the value of p

$$p = \dots\dots\dots (1)$$

$$5^r = 1$$

(d) Write down the value of r

$$r = \dots\dots\dots (1)$$

(Total for Question 5 is 4 marks)



DO NOT WRITE IN THIS AREA

DO NOT WRITE IN THIS AREA

DO NOT WRITE IN THIS AREA

6 The diagram shows triangle ABC

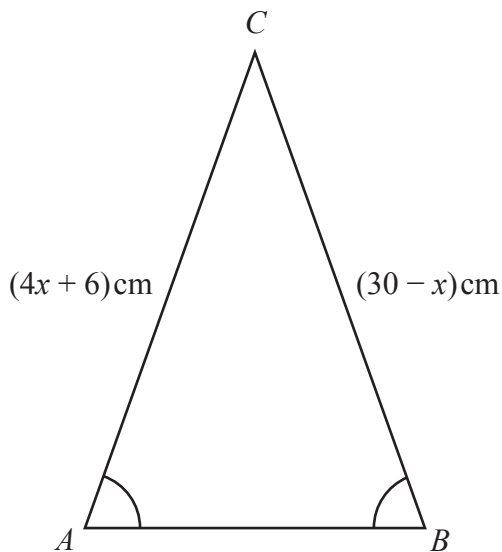

Diagram **NOT** accurately drawn

$$CA = (4x + 6) \text{ cm} \quad CB = (30 - x) \text{ cm} \quad \text{angle } CAB = \text{angle } CBA$$

Work out the value of x

$$x = \dots\dots\dots$$

(Total for Question 6 is 3 marks)



- 7 Change a speed of 40 metres per second to a speed in kilometres per hour.
Show your working clearly.

DO NOT WRITE IN THIS AREA

DO NOT WRITE IN THIS AREA

..... kilometres per hour

(Total for Question 7 is 3 marks)

DO NOT WRITE IN THIS AREA



8

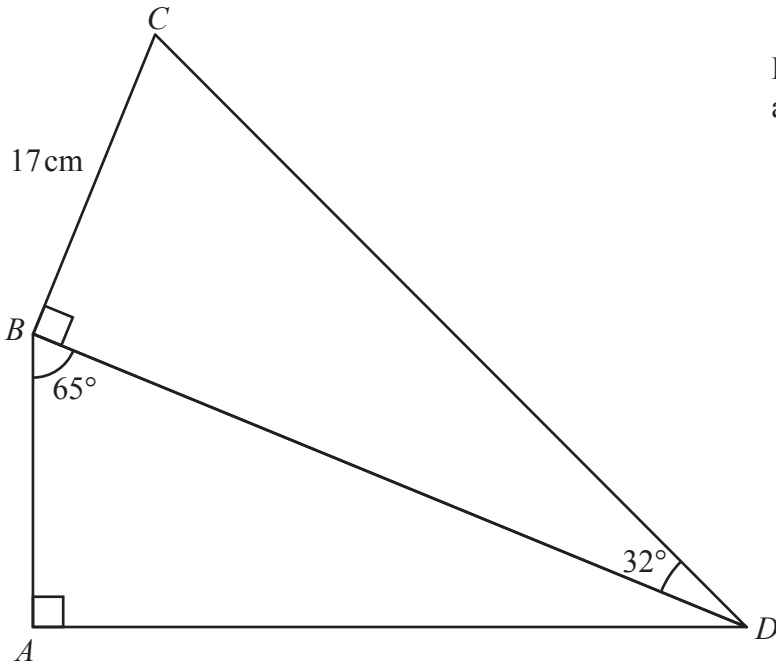

Diagram **NOT** accurately drawn

ABD and *BCD* are right-angled triangles.

$$\text{angle } ABD = 65^\circ \quad \text{angle } CDB = 32^\circ \quad BC = 17 \text{ cm}$$

Work out the length of *AD*

Give your answer correct to 3 significant figures.

..... cm

(Total for Question 8 is 4 marks)

DO NOT WRITE IN THIS AREA

DO NOT WRITE IN THIS AREA

DO NOT WRITE IN THIS AREA



P 8 1 6 3 5 A 0 9 2 8

9 (a) Simplify $(5k^3n^4)^2$

.....
(2)

(b) Factorise fully $12m^2y^4 + 18m^3y$

.....
(2)

(c) (i) Factorise $x^2 - 13x + 42$

.....
(2)

(ii) Hence, solve $x^2 - 13x + 42 = 0$

.....
(1)

(Total for Question 9 is 7 marks)



DO NOT WRITE IN THIS AREA

DO NOT WRITE IN THIS AREA

DO NOT WRITE IN THIS AREA

10 The diagram shows a rectangular sheet of metal.

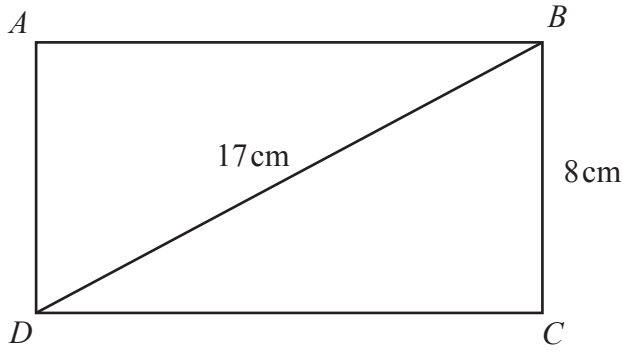

Diagram NOT accurately drawn

$$BC = 8 \text{ cm} \quad DB = 17 \text{ cm}$$

The sheet of metal lies flat on a table.
 The force exerted by the sheet of metal on the table is 150 newtons.

Work out the pressure on the table due to the sheet of metal.
 Show your working clearly.

$\text{pressure} = \frac{\text{force}}{\text{area}}$
--

..... newtons/cm²

(Total for Question 10 is 5 marks)



11 The probability that it will snow on Saturday is 0.2

If it snows on Saturday, the probability that it will snow on Sunday is 0.35

If it does not snow on Saturday, the probability that it will snow on Sunday is 0.4

(a) Use this information to complete the probability tree diagram.

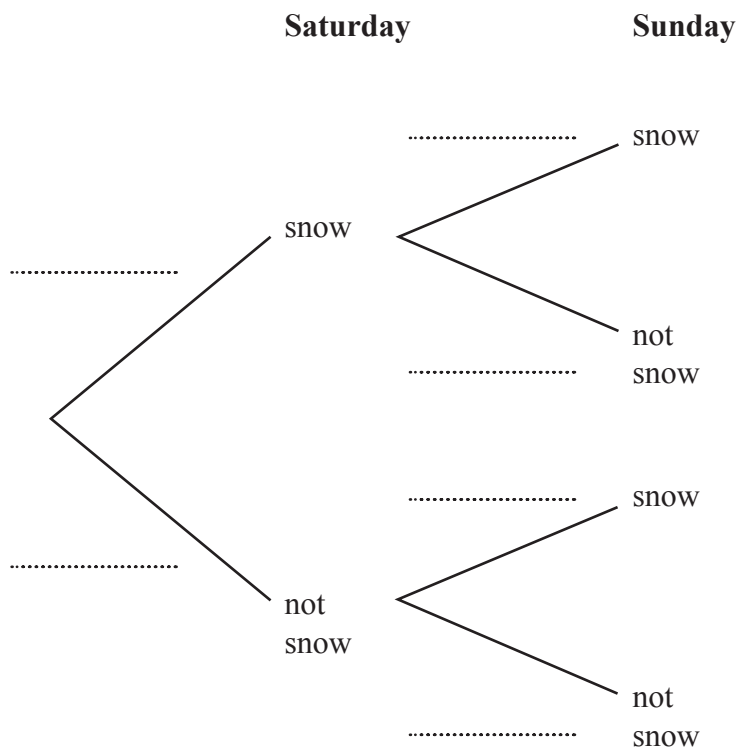

(2)

(b) Work out the probability that it will snow on both Saturday and Sunday.

.....
(2)

(Total for Question 11 is 4 marks)



DO NOT WRITE IN THIS AREA

DO NOT WRITE IN THIS AREA

DO NOT WRITE IN THIS AREA

12 (a) Solve $\frac{5a + 8}{3} - \frac{2a + 5}{4} = 23$
Show clear algebraic working.

$a = \dots\dots\dots$ (4)

(b) Express $\left(\frac{\sqrt{y}}{3}\right)^{-1}$ in the form cy^n where c and n are numbers to be found.

$\dots\dots\dots$ (2)

(Total for Question 12 is 6 marks)



13 In the diagram, AB represents a vertical tower and CD represents a vertical building.

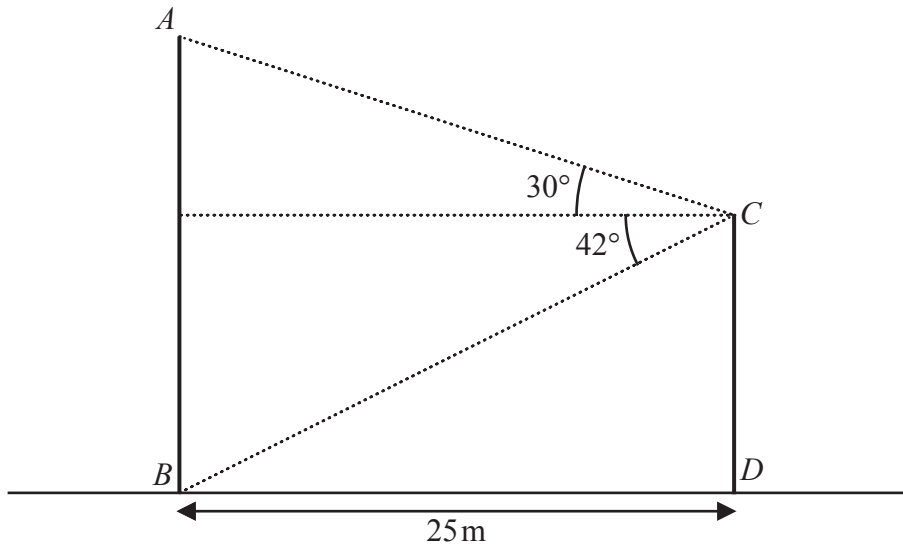

Diagram **NOT** accurately drawn

The bottom of the tower, B , and the bottom of the building, D , are on horizontal ground such that $BD = 25\text{ m}$

The angle of elevation of A from C is 30°
 The angle of depression of B from C is 42°

- (a) Work out the height of the tower AB
 Give your answer correct to one decimal place.

..... m

(3)

DO NOT WRITE IN THIS AREA

DO NOT WRITE IN THIS AREA

DO NOT WRITE IN THIS AREA



DO NOT WRITE IN THIS AREA

DO NOT WRITE IN THIS AREA

DO NOT WRITE IN THIS AREA

- (b) Work out the angle of elevation of A from D
Give your answer correct to one decimal place.

.....
(2)

(Total for Question 13 is 5 marks)

- 14 Use algebra to show that the recurring decimal $0.6\dot{1}\dot{2} = \frac{101}{165}$

(Total for Question 14 is 2 marks)



- 15 (a) Solve $3x^2 + 4x - 18 = 0$
Show your working clearly.
Give your solutions correct to 3 significant figures.

.....
(3)

- (b) Expand and simplify $(2x - 3)(x + 4)(x - 1)$

.....
(3)

(Total for Question 15 is 6 marks)



DO NOT WRITE IN THIS AREA

DO NOT WRITE IN THIS AREA

DO NOT WRITE IN THIS AREA

16 $\sqrt{96} = 2\sqrt{k}$

(a) Find the value of k

$k = \dots\dots\dots$
(1)

(b) Show that $\frac{8}{3 - \sqrt{5}}$ can be written in the form $a + \sqrt{b}$ where a and b are integers.

Show each stage of your working.

(3)

(Total for Question 16 is 4 marks)



17 Kannika has 9 counters.
There is a number on each counter.



Kannika puts the 9 counters in a bag.
She takes at random a counter from the bag and does not replace the counter.
She then takes at random a second counter from the bag.

Work out the probability that the sum of the numbers on the two counters
is less than 5

.....
(Total for Question 17 is 3 marks)



DO NOT WRITE IN THIS AREA

DO NOT WRITE IN THIS AREA

DO NOT WRITE IN THIS AREA

18 (a) Express $2x^2 - 12x + 23$ in the form $a(x - b)^2 + c$ where a , b and c are integers.
Show clear algebraic working.

.....
(3)

(b) Hence, state the least value of $2x^2 - 12x + 23$

.....
(1)

(Total for Question 18 is 4 marks)



19 The diagram shows a pentagon $ABCDE$

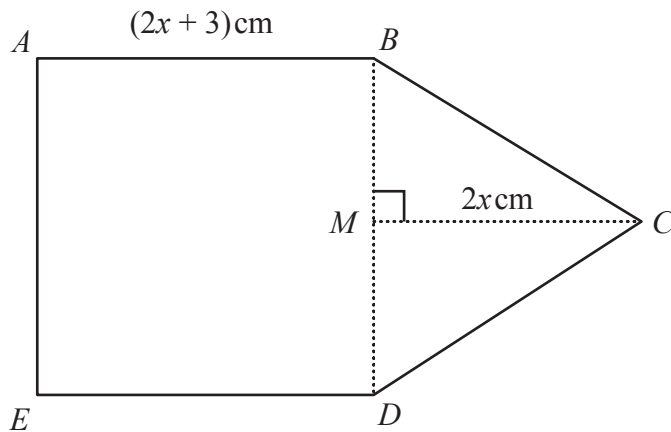

Diagram **NOT**
accurately drawn

$ABCDE$ is made from a square $ABDE$ and a triangle BCD
 M is the midpoint of BD

$$AB = (2x + 3) \text{ cm} \quad MC = 2x \text{ cm} \quad \text{angle } BMC = 90^\circ$$

The area of pentagon $ABCDE$ is 84 cm^2

Work out the area of square $ABDE$
Show clear algebraic working.

DO NOT WRITE IN THIS AREA

DO NOT WRITE IN THIS AREA

DO NOT WRITE IN THIS AREA



DO NOT WRITE IN THIS AREA

DO NOT WRITE IN THIS AREA

DO NOT WRITE IN THIS AREA

..... cm²

(Total for Question 19 is 5 marks)

Turn over for Question 20



20 The diagram shows cuboid $ABCDEFGH$

Diagram **NOT**
accurately drawn

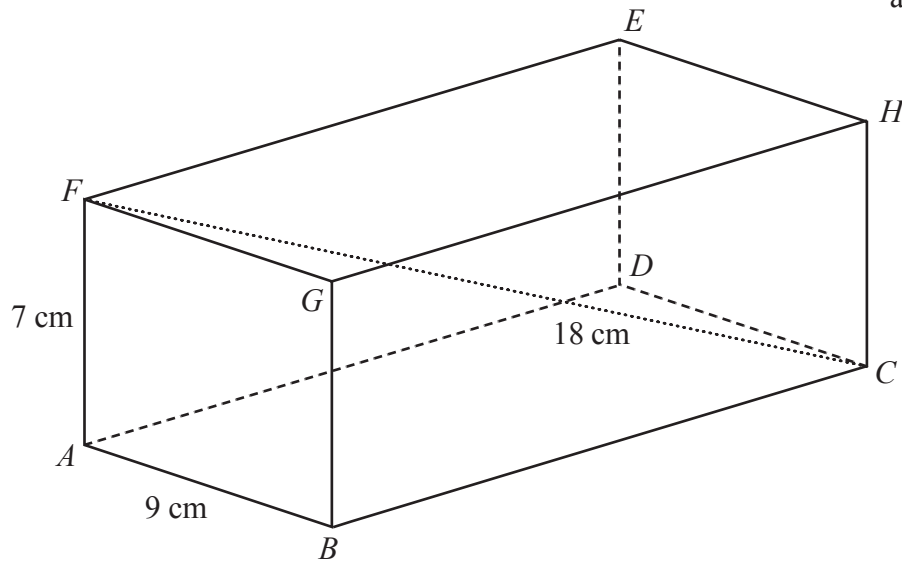

$AB = 9 \text{ cm}$ $AF = 7 \text{ cm}$ $FC = 18 \text{ cm}$

Calculate the length of BC

Give your answer correct to 3 significant figures.

..... cm

(Total for Question 20 is 3 marks)

DO NOT WRITE IN THIS AREA

DO NOT WRITE IN THIS AREA

DO NOT WRITE IN THIS AREA



21 The histogram shows information about the ages of the members of a chess club.

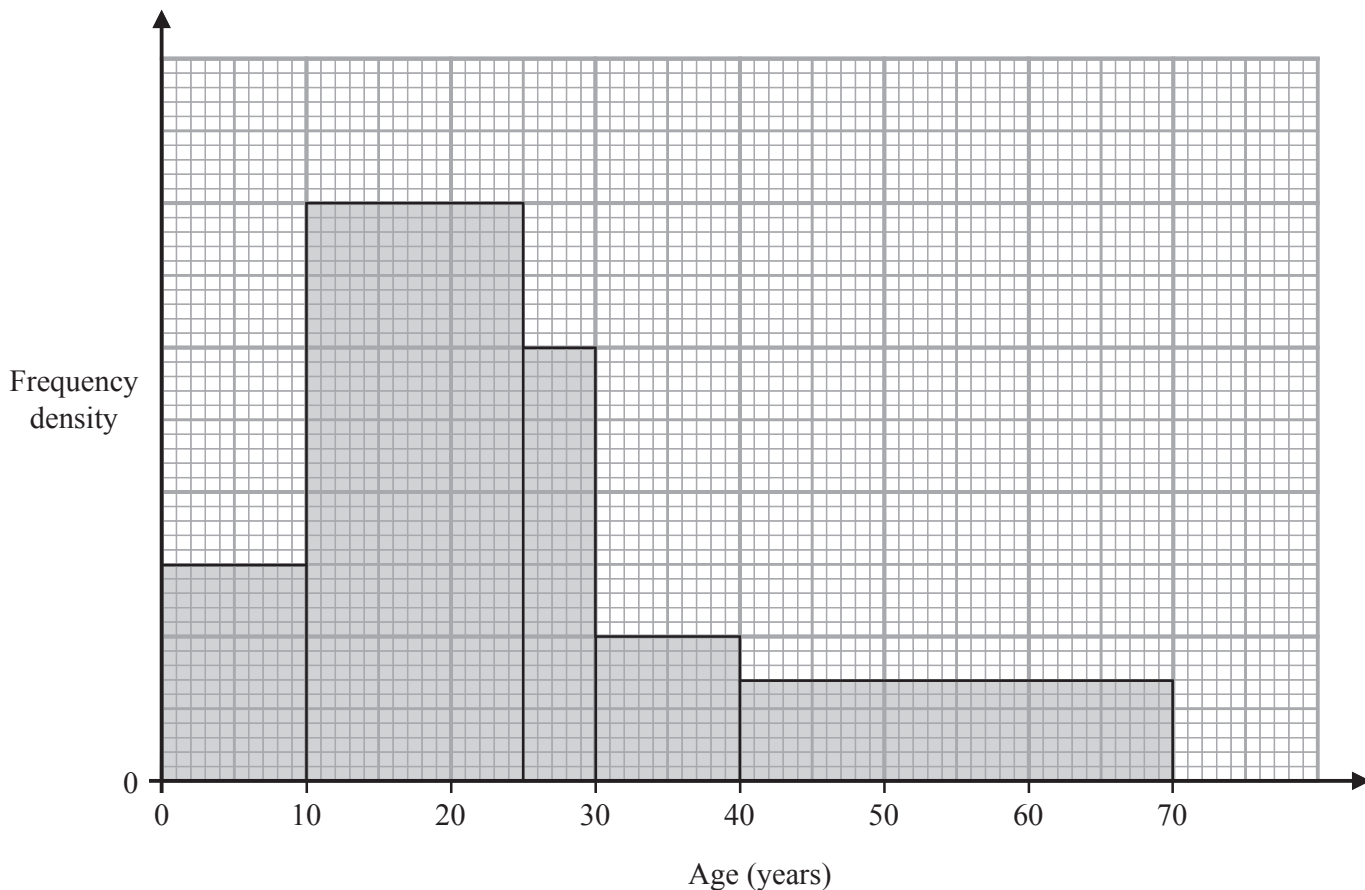

There are 60 members aged between 10 and 25

There are no members older than 70

Work out an estimate for the number of members who are over 35 years of age.

(Total for Question 21 is 3 marks)



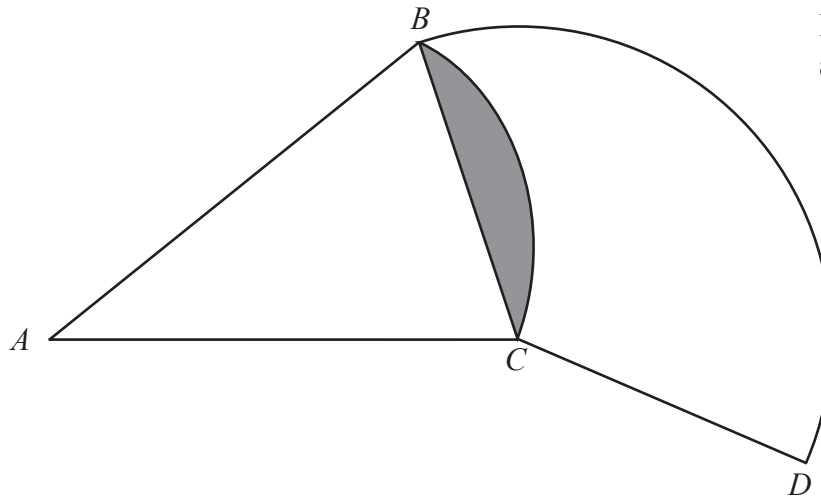

Diagram **NOT**
accurately drawn

BAC is a sector of a circle, centre A

BCD is a sector of a circle, centre C

Angle $BAC = 40^\circ$

Angle $BCD = 130^\circ$

Area of shaded segment = 28 cm^2

Find the length of the arc BD

Give your answer correct to 3 significant figures.



DO NOT WRITE IN THIS AREA

DO NOT WRITE IN THIS AREA

DO NOT WRITE IN THIS AREA

..... cm

(Total for Question 22 is 6 marks)

Turn over for Question 23



23 A circle C has centre $(3q, 4q)$ where q is an integer.

The straight line with equation $y = -\frac{5}{4}x + \frac{21}{4}$ is the tangent to C at the point $(p, p + 3)$

where p is an integer.

Work out the radius of C

Give your answer in the form \sqrt{a} where a is an integer.

Show your working clearly.

DO NOT WRITE IN THIS AREA

DO NOT WRITE IN THIS AREA

DO NOT WRITE IN THIS AREA



DO NOT WRITE IN THIS AREA

DO NOT WRITE IN THIS AREA

DO NOT WRITE IN THIS AREA

.....
(Total for Question 23 is 5 marks)

Turn over for Question 24



P 8 1 6 3 5 A 0 2 7 2 8

24 Write $(2x - 1) + \frac{2x^2 - 5x - 12}{x^2 - 16} \times \frac{x^2 + 4x}{6x^2 + 11x + 3}$ as a single fraction in its simplest form.

Show clear algebraic working.

DO NOT WRITE IN THIS AREA

DO NOT WRITE IN THIS AREA

DO NOT WRITE IN THIS AREA

.....
(Total for Question 24 is 4 marks)

TOTAL FOR UNIT IS 100 MARKS

